

FNR80series

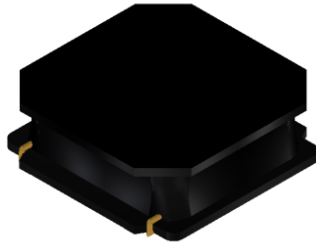

CONSTRUCTION

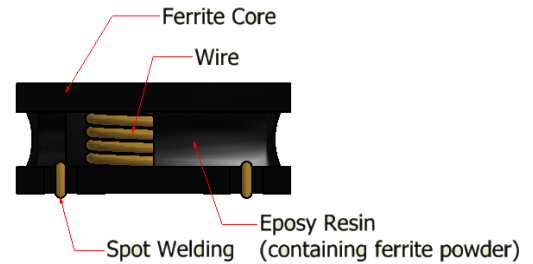

FEATURES

Magnetically structure
Low DC resistance
Large Current Capability

APPLICATIONS

Hard Disk Drives
Car audio equipment
Tablet PC
Navigation system
SSD
Touch Panel

SPECIFICATIONS

Operating temperature range	-40 to +125°C
Storage temperature range	Under 25°C
Packaging style	Taping
Quantities	1,000 pieces/reel

SHAPE AND DIMENSIONS

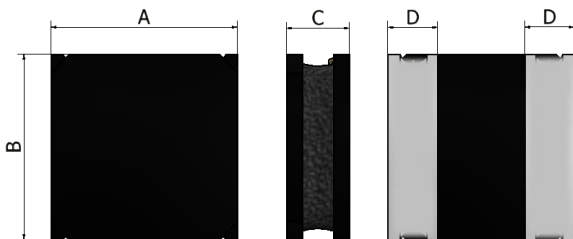

RECOMMENDED PATTERN

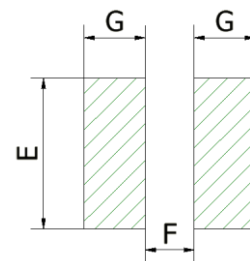

(Unit: mm)

TYPE	A	B	C	D	E	F	G
FNR8040	8.0±0.2	8.0±0.2	4.2max	1.6±0.1	8.2	3.9	1.9

PRODUCT IDENTIFICATION (ex.)

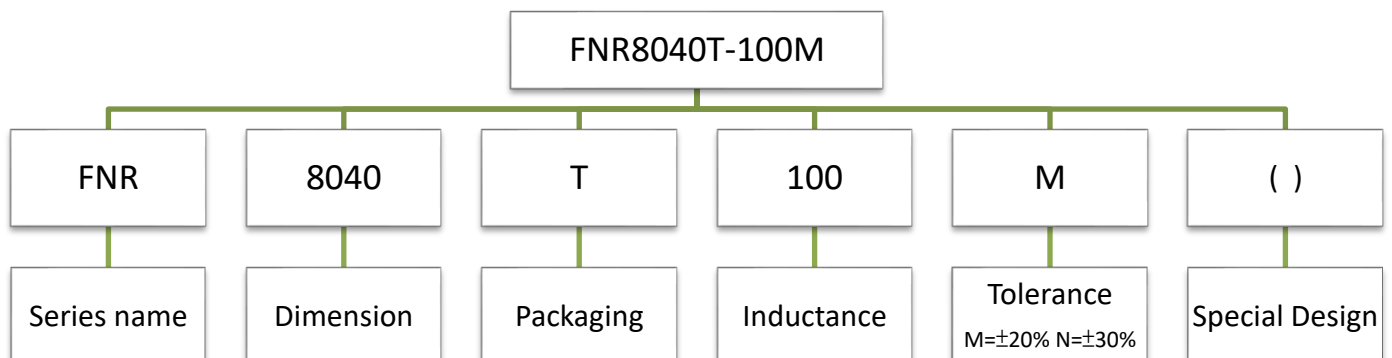

ELECTRICAL CHARACTERISTICS

Part No.	Inductance (uH)	Inductance tolerance	Test Frequency (kHz)	DC Resistance (Ω) ±20%	Saturation current Isat(mA)		Temperature rise current Irms(mA)	
					Typ.	Max.	Typ.	Max.
FNR8040T-R90N	0.9	±30%	100	6.0	11000	9000	7800	7200
FNR8040T-1R4N	1.4	±30%	100	7.0	9000	8000	7000	6600
FNR8040T-1R8N	1.8	±30%	100	9.0	8000	7000	6500	6200
FNR8040T-2R0N	2.0	±30%	100	9.0	7400	6800	6300	6000
FNR8040T-2R2N	2.2	±30%	100	9.0	7400	6800	6300	6000
FNR8040T-2R5N	2.5	±30%	100	12.0	6400	6000	5400	5100
FNR8040T-3R3N	3.3	±30%	100	15.0	5300	5000	4900	4700
FNR8040T-3R6N	3.6	±30%	100	15.0	5300	5000	4900	4700
FNR8040T-4R7N	4.7	±30%	100	18.0	4700	4400	4100	3800
FNR8040T-6R8N	6.8	±30%	100	25.0	4000	3700	3700	3500
FNR8040T-100M	10.0	±20%	100	34.0	3400	3100	3100	2900
FNR8040T-150M	15.0	±20%	100	50.0	2700	2500	2400	2200

*The saturation current value (Isat) is the DC current value having inductance decrease down to 30% (at 25°C)

*The temperature rise current value (Irms)is the DC current value having temperature increase up to 40°C (at 25°C)

*Rated current: smaller value of either Isat or Irms.

RECOMMENDED SOLDERING CONDITIONS

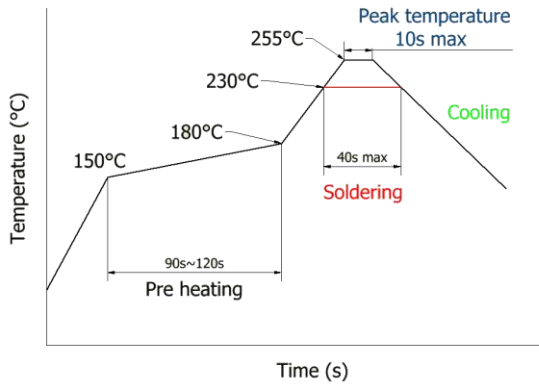

PACKAGE

(1) Taping specifications

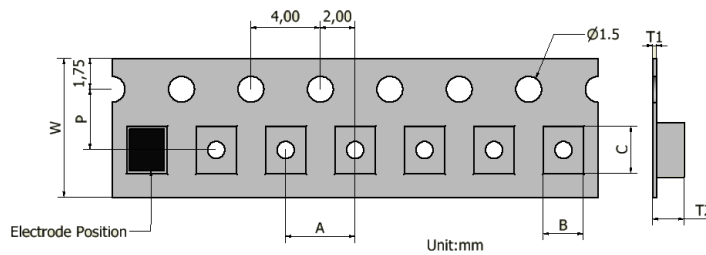

Type	W	P	A	B	C	T1	T2
FNR8040	16	7.5	12	8.3	8.3	0.35	4.3

(2) Reel Specifications

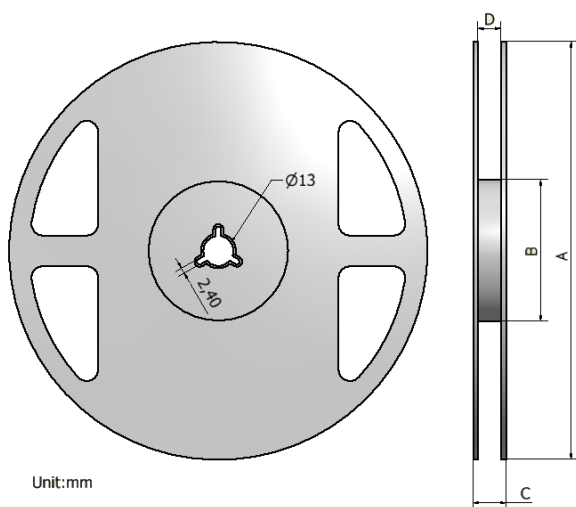

Type	A	B	C	D	Q'ty/Reel
FNR8040	330±2.0	100±1.0	20±1.0	16±0.15	1000

Label

Wire Wound Power Inductors
 FNR80□□T-□□□M/N
 □□□□PCS
 Lot No. _____
 FUMIWA TECHNIAL CO., LTD.

Type	Q'ty
PCS/Reel	1000
Reel/inner Box	4000
Inner Box/Carton	20000